

AMERICAN CATERING EQUIPMENT

SINGLE AND DOUBLE BOWL SINKS adjustable position undershelf 304 stainless steel

Heavy duty quality, robust construction, good aesthetic style, safety finish is easy to maintain and keep clean. Suitable for any harsh hard working environment where high standard of hygiene is essential.

There are no exposed bolts, brackets or components. Designed for kitchens, food service areas, hospitals, laboratories, butchers, abattoirs, bakery, dairy, fishmonger, food processing, veterinary services and any other area where stringent standards are required.

The quality of these sinks is certified worldwide by:

- NSF** (National Sanitary Foundation)
- ANSI** (American National Standards Institute)
- SSC** (Standards Council of Canada)

Sinks are available three lengths one width, single or double bowl, standard depth or extra deep, single or double drainer subject to model. Corner drain with stainless steel overflow tube and guard as standard.

All sinks are dispatched easy to handle and store cartons ready for on site assembly.

Optional Extras

- SPTC** Pillar taps - 1/2" - Cross-head Handles
- SPTL** Pillar taps - 1/2" - Lever Handles
- MXDC** Mixer Tap - 1/2" - Cross-head Handles
- MXDL** Mixer Tap - 1/2" - Lever Handles
- MXDW** Mixer Tap - 1/2" - Elbow Lever Handles
- PR30** Overspray complete with Pot-filler
- FF** 304 Stainless steel flanged feet
3 1/2" (90 mm) flange



SSRB424-2 SINK
ADJUSTABLE UNDERSHELF
OPTIONAL SPTC PILLAR TAPS



SSCB624-2 SINGLE BOWL SINK
ADJUSTABLE UNDERSHELF
OPTIONAL PR30 OVERSPRAY



SSDCB824-2 DOUBLE BOWL SINK
ADJUSTABLE UNDERSHELF
OPTIONAL PR30 OVERSPRAY
OPTIONAL SPTC PILLAR TAPS



AMERICAN CATERING EQUIPMENT (UK) LIMITED
5 CHANTRY COURT
SOVEREIGN WAY
CHESTER WEST
CHESTER CH1 4QN
UNITED KINGDOM

TEL: + 44 (0) 1244 381281
FAX: + 44 (0) 1244 381700
OFFICE: FSE@ACE-UK.COM
PARTS: PARTS@ACE-UK.COM
WEBSITE: WWW.ACE-UK.COM



SINGLE AND DOUBLE BOWL SINKS

adjustable position undershelf

Technical Drawing

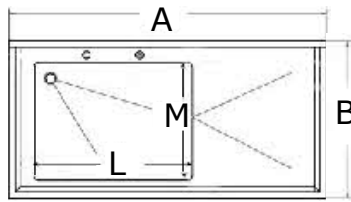
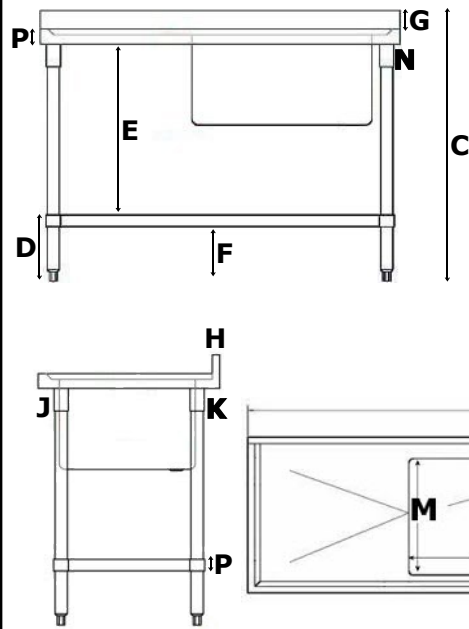

SSLB424

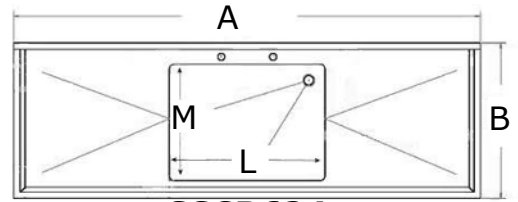

SSCB624

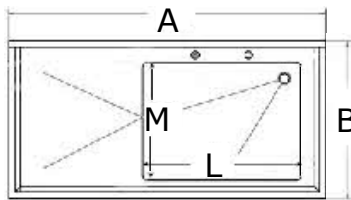

SSRB424

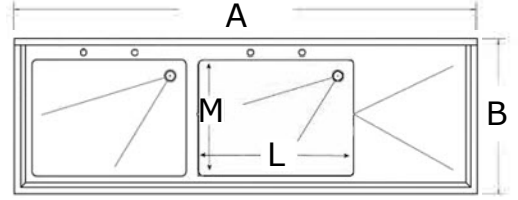

SSDLB624

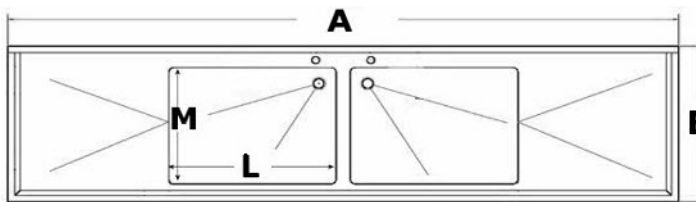

SSDCB824

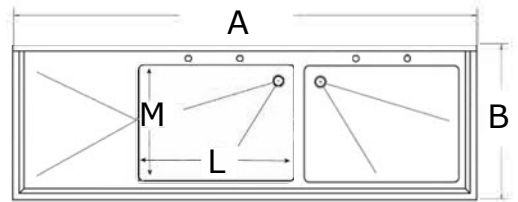

SSDRB624

Dimensions	millimeters
Nominal length	A 1200 1800 2400
Nominal width	B 610
Height	C 900
Shelf height	D Adjustable
Shelf clearance	E Adjustable
Shelf clearance	F Adjustable
Upstand height	G 50
Upstand tiling return	H 20
Top overhang - front	J 55
Top overhang - rear	K 55
Bowl Length	L 610
Bowl Width	M 457
Top overhang - ends	N 22
Top and shelf turndown	P 50

Construction	
Top	304 Stainless steel 1.2 mm (18 gauge)
Stiffeners	
Undershelf	
Legs	304 Stainless steel tube 40 mm o/d
Adjustable feet	304 Stainless steel

Model numbers for ordering:

SSLB424-1 is sink unit with 250 mm standard bowl to left and right hand drainer 610 mm wide, 1200 mm long, 900 mm high

SSRB424-2 is sink unit with 300 mm extra deep bowl to right and left hand drainer 610 mm wide, 1200 mm long, 900 mm high

Bowl size:

All bowls are 610 mm long, 457 mm wide
 Standard bowl 250 mm deep or extra deep bowl 305 mm deep
 38 mm corner drain hole with stainless steel overflow pipe and guard
 25 mm tap holes at 205 mm centers

Sink Model	Length					
	1200	1800	2400			
Standard Bowl	SSLB424-1	SSRB424-1	SSCB624-1	SSDLB624-1	SSDRB624-1	SSBCD824-1
Extra Deep Bowl	SSLB424-2	SSRB424-2	SSCB624-2	SSDLB624-2	SSDRB624-2	SSDCB824-2
Nominal Packed Dimensions						
650 mm Wide	1265		1865		2490	
350 mm Deep	1265		1865		2490	
Approx Packed Weight						
	40 kg	47 kg	50 kg	60 kg		
Optional Extras						
SPTC or SPTL	1/2" Pillar taps - cross-head or lever handles					
MXDC or MXDL or MXDW	1/2" Mixer tap - cross-head or lever or elbow lever handles					
PR30	1/2" Overspray unit complete with pot-filler					
Flanged feet	304 Stainless steel adjustable bolt down feet - 90 mm (3 1/2") flange					
Specifications subject to continuous improvement program						



AMERICAN CATERING EQUIPMENT (UK) LIMITED
 5 CHANTRY COURT
 SOVEREIGN WAY
 CHESTER WEST
 CHESTER CH1 4QN
 UNITED KINGDOM

TEL: + 44 (0) 1244 381281
 FAX: + 44 (0) 1244 381700
 OFFICE: FSE@ACE-UK.COM
 PARTS: PARTS@ACE-UK.COM
 WEBSITE: WWW.ACE-UK.COM

